

Choice Criteria for Halal Financing: Religiosity as Mediator

Siti Nor Amira Mohamad^{1*}, Mohamad Yazis Ali Basah²

¹*Academy of Contemporary Islamic Studies, Universiti Teknologi MARA,
40450 Shah Alam, Malaysia*

²*Faculty of Economics & Muamalat, Universiti Sains Islam Malaysia,
71800 USIM Bandar Baru Nilai, Malaysia*

*Corresponding Authors
sitinoramira@uitm.edu.my*, yazis@usim.edu.my

Received: 30 April 2022

Accepted: 12 October 2022

Online First: 15 November 2022

ABSTRACT

This paper aims to examine the factors of Muslims' intention toward halal financing by considering religiosity as a mediator. The data were collected through a survey of 220 Muslims in Malaysia and were analyzed using the Structural Equation Modelling (SEM) technique. The returned survey was N=211, and the results showed that attitudes and subjective norms positively affect the intention to use halal financing. Religiosity has a mediation effect on the intention to use halal financing. Managers and marketers of Islamic banks may benefit from the findings of this study, which provide insight into the factors that should be considered to promote halal financing. The findings contribute to the literature on halal financing products by demonstrating the drivers of intention to use halal financing. The study also extends the literature by testing the mediating role of religiosity. Furthermore, the study extends the Theory of Reasoned Action (TRA) in the context of halal financing by introducing religiosity as a potential driver of intention and mediator effect.

Keywords: Halal Financing, Islamic Banking & Finance, Religiosity, Structural Equation Modelling (SEM), Theory of Reasoned Action (TRA)

INTRODUCTION

The operationalization of the conventional banking system is prohibited in Islam, primarily based on riba's activities, and Muslims are banned from engaging in it. Al-Quran verse 39 in Surah Al-Rum has stated the prohibited of

riba':

“And whatever you lay out as usury in order that it may increase on people’s property (dhikr you do without wishing to reach Allah while you are living), it shall not increase in the Presence of Allah (it does not bring the glorious lights into your soul’s hearts and does not increase them). Whatever you give in Zakat (dhikr you do) seeking Allah’s Face (seeking to reach Allah), it is these that shall get manifold (increase the glorious lights in the souls’ hearts)”

Surah Al-Rum, 30: 39

This prohibition of riba' in Islam has established an opportunity for the introduction of halal financial products that can be used to convince the financial needs of those customers who are diffident to engage in riba' for Is the Islamic banking system since it has unique features such as the practices are based on the principles of the prohibition of riba', gambling, speculation, pornography, and alcoholic beverages, which are against Islamic principles.

The 1983 Islamic Banking Act served as the foundation for establishing the first full-fledged Islamic bank. The advent of Islamic "windows," which let conventional financial institutions provide banking services and products following Shariah, allowed the Islamic banking sector to develop naturally. This made it easier to establish a dual-financial system where Islamic banking coexists with the mainstream financial system. After over three decades, Malaysia's Islamic banking sector currently boasts a critical mass of local and foreign financial institutions and a broad spectrum of cutting-edge goods and services. To improve commercial and financial ties with other major financial centers worldwide, Malaysia's Islamic financial community began to expand its business offerings internationally.

According to a Fitch rating study, Islamic banks' credit profiles will stay stable in 2022. As operating revenue and credit expenses return to pre-pandemic levels, banks' capital levels should remain constant. In 2022, the business will be kept afloat by high public demand for Islamic products and long-standing government and regulatory support. Malaysian Islamic financing growth remained strong in 2021, underpinned by solid home finance demand and increased working capital lending. This trend will likely continue in 2022, along with a more substantial economic recovery (2022F GDP growth: 6.5 percent, 2021E GDP growth: 3.6 percent) and enhanced asset-quality clarity as Covid-19 relief measures are phased out.

Furthermore, asset quality has a higher share exposure in the home sector and small-medium companies than traditional competitors. The government has

enacted a moratorium and other measures to assist disadvantaged organizations such as the B40, which may cause a delay in the credit quality crystallization of their portfolio. As a result, the non-performing loan ratio has stayed relatively steady at 1.3 percent, and liquidity performance may be another possible impediment to Islamic banking's financing growth recovery this year. Given the great success of Malaysia's Islamic banking system, the following topic must be addressed: what are the selection criteria for Halal Financing among Malaysian Muslims?

The prevalence of halal financing has drawn more academic attention (Wulandari et al., 2016; Yaya et al., 2021). According to a study of these studies, there is not much empirical research on halal financing in the literature. Instead, earlier studies (Sharif et al., 2020; Hati et al., 2021; Thaker et al., 2021) have concentrated on other halal items that are fundamentally unrelated to halal financing. The main halal financing options provided by Islamic banks in Malaysia, such as Tawarruq, Ijarah, Bai Bithaman Ajil, Musharakah, and Mudharabah, have not been successful in drawing in many Malaysian residents. Therefore, research on the motives for using halal financing is needed, which is the focus of the current study.

Previous research has employed the Theory of Reasoned Action (TRA) to explain consumers' intentions toward this context, and its capacity to explain customers' intentions in this context has been established (Jamshidi & Hussin, 2018; Effendi et al., 2021). In order to understand Malaysian Muslims' desire to employ halal financing, this study also uses the TRA. There is mounting evidence that, in the context of Islamic finance, religion has a significant role in determining behavioural intentions (Khan et al., 2020; Bananuka et al., 2020). Thus, to improve the capacity to comprehend the desire to employ halal financing, the current study attempts to extend the TRA by integrating religion as a predictive variable.

Researchers have shown that the degree of Muslim customers' religion significantly impacts their behaviour (Kusumawati et al., 2019; Khan et al., 2020; Bananuka et al., 2020). Past research in Islamic finance has also shown that consumers' intentions to utilise Islamic banking goods and services are significantly influenced by their religious affiliation (Bananuka et al., 2020; Suhartanto et al., 2020; Alzadjal et al., 2021). Understanding the elements influencing halal finance among Muslims and taking religion into account as one of those aspects is crucial for Islamic bank marketers who want to promote halal financing by focusing on Muslim consumers. Therefore, this study looked into the mediating role of religion.

The results of this study add to the body of literature in three ways. First, examining the selection criteria for halal financing among Muslims in Malaysia

adds to the knowledge of halal financing products. Second, by including religion as one of the variables towards intention to utilise halal financing, the study expands the TRA. Thirdly, by examining the mediating role of religion, the study adds to the body of literature. Findings could aid bank managers, marketers, and politicians in promoting various halal finance more successfully.

Empirical Studies

One of the requirements for achieving Maqasid Shariah's goals is the necessity for halal financing. One of the businesses that provide its customers with halal financial goods, including Tawarruq, Ijarah, Bai Bithaman Ajil, Musharakah, and Mudharabah, is Islamic banking (Mohamad et al., 2014) since these goods boost the value and effectiveness of Islamic banks in comparison to other types of products and raise their crisis resilience.

In order to discover customers who are more or less acceptable, practitioners have made significant progress in segmenting their databases as a result of previous research on intention to use as well as behaviour that has been successful (Magli et al., 2022). However, the expected customers' willingness to use halal financing when they transfer to competitors is still an unspecified goal (Mohamad et al., 2019). The severity of this problem is highlighted by empirical evidence that indicates that many individuals might still switch to a rival for several reasons. Furthermore, it is still debatable if contributions to halal financing help gain acceptability and if they will be put to the intended use.

Researchers have yet to be persuaded by an empirical study on halal financing that there is a low degree of acceptance for these forms of contracts. One of the causes is their lack of attitudes and perceptions of the "Islamicity" of the objects' intricacy (Amin et al., 2014; Basah & Mohamad, 2021). Shariah compliance is another requirement for establishing the purpose and happiness of finance (Amin, 2017). In addition, he pointed out that consumers, particularly Muslims, have a religious obligation that they may employ to further their objectives and satisfy their requirements. Religion and arbitrary standards both affect purpose.

In Malaysia's banking market, customers of Islamic banks can simply move to conventional banks that offer traditional lending procedures if not all-important consumer acceptability characteristics are considered. Much research has revealed that the intention to use depends on attitudes, subjective standards, and religious considerations (Mohamad et al., 2016; Amin, 2017; Kusumawati

et al., 2019; Khan et al., 2020; Bananuka et al., 2020). A model spanning these variables can only be generalised if its parameters have been appropriately adjusted based on the study circumstances.

Because it satisfies one's behavioural purpose to use and grow loyal, it appears complex to measure choice criteria for halal financing. Therefore, a thorough analysis is needed to determine the best way to replicate the TRA model using the rationality of religion as a moderating influence. As a result, intent to use should be quantified using particular characteristics that change from one country to the next. This means that halal financing sector participants such as banks, regulators, central banks, and merchants must apply a unique measurement specific to the current scenario.

There have been studies looking at what influences people's decisions to utilise halal financing, but they were not all-encompassing. Perspectives on the general public, consumers, or clients, as well as their intentions in selecting only a few forms of financing, are some of the issues that were looked into. However, none of the research described above was thorough enough to address every component of the financing products, the Muslim setting, and the lack of sufficient attention to religion's role as a mediation effect.

Since there is a dearth of pertinent literature, the researcher must utilise other contextual settings to construct selection criteria for a halal financing model, using religion as the mediator effect. This guarantees that the measurement created is founded on a solid theoretical and conceptual framework.

Theoretical Development

Consumer behaviour and marketing have long explored intention behaviour theories. The theories are primarily employed to research behavioural components that may influence decision-making. The Theory of Reasoned Action (TRA), created by Martin Fishbein and Icek Ajzen in 1967, is commonly used to analyse human intention. It focuses on an individual's conduct and desire to carry out a given act and helps to explain and predict human behaviour. In TRA, there are two presumptions. The bulk of human behaviours are motivated by volitional control, and behavioural intentions govern the actions taken by individuals (Fishbein & Ajzen, 1977).

TRA emerged from psychology and has been applied to explain human behaviour across many areas (Ha, 1998; Zhikun & Fungfai, 2009; Troudi &

Bouyoucef, 2020). Three concepts—behavioural intention, attitude, and subjective norms—combine to make up TRA (Figure 1).

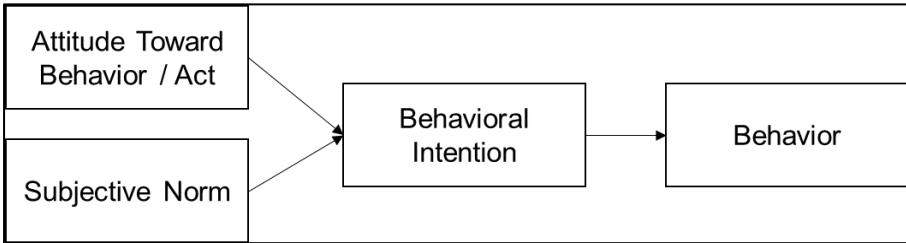

Figure 1. Theory of Reasoned Action (TRA). Source: Fishbein & Ajzen (1967)

This theory holds that attitudes and subjective norms shape an individual's behavioural intentions, which are those that lead to conduct. Since Muslims intend to employ halal financing, the current study uses TRA to explain this aim. A person's attitude and subjective norms are the sources of behavioural intention, claims TRA. Attitudes and arbitrary standards impact this study's intention to employ halal financing. In order to further develop TRA as a possible mediator, contextual elements like religion were also introduced based on the research.

Conceptual Framework & Hypotheses Development

This study's theoretical approach is based on the TRA model created by Fishbein and Ajzen. This model has been modified for this study in order to describe the purpose better to utilise halal financing. Previous research has found that TRA has enough capacity to explain consumer behaviour in the context of financing. In this study, the TRA model is expanded by including another variable, religiosity (Figure 3), which has been proven relevant in multiple previous studies on patronizing Islamic banking and the intention to utilise various goods and services. Religion was also regarded as a possible mediator.

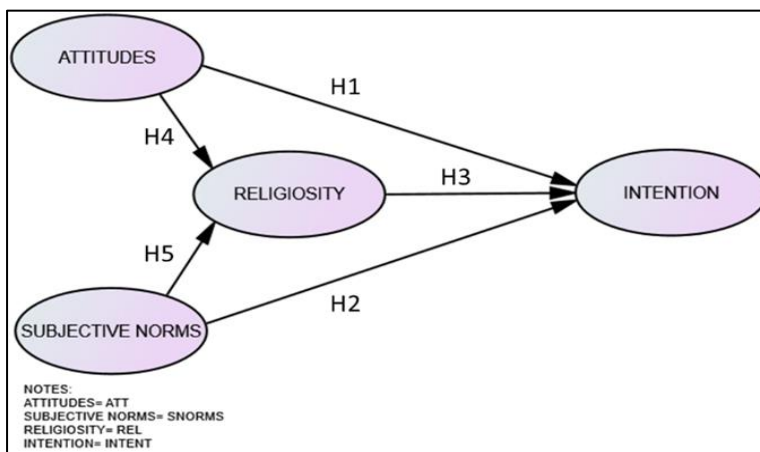

Figure 2. Conceptual Model Development

Attitudes

In theoretical development, attitudes are the most significant value in gauging intention. ATT denotes one's subjective views about the aim. This belief describes how a person feels their activity will result in a specific outcome. An examination of the direction of beta coefficient associations indicated that practically all findings favour attitudes toward the intention. Empirical data from several investigations confirm this. Positively significant outcomes, for example, were discovered (Bananuka et al., 2019; Himel et al., 2021; Mohamad et al., 2021; Jusoh et al., 2021). As a result, the following hypotheses are developed: -

H1: Attitudes have a positive effect on the intention to use halal financing

Subjective Norms

In terms of whether or not a person should engage in given conduct, subjective norms are described as their view of how others who are extremely important to and close to them feel about it (Fishbein & Ajzen, 1967). According to a significant number of previous research, there is a strong link between subjective norms and intention. According to a large number of other research, subjective standards significantly influence intention (Bananuka et al., 2019; Johan et al., 2020; Himel et al., 2021). Given the studies mentioned above, the following hypotheses were developed:

H2: Subjective Norms have a positive effect on the intention to use halal

financing.

Religiosity

Religiosity is the degree to which a person is devoted to and committed to their faith, as well as the degree to which their conduct reflects this. Numerous studies have found that religion and intention are significantly related (Suhartanto, 2019; Suhartanto et al., 2020; Bananuka et al., 2020).

As a result, this study suggested that religion may have a mediation influence on relationships between attitudes and subjective norms regarding the aim of halal finance. On the other hand, it is anticipated that religiosity has a mediating influence on halal financing using the same reasoning that suggests that religion has a significant role in the lives and decisions of religious people (Amin, 2017; Bananuka et al., 2019; Junaidi et al., 2021). Religious persons may choose to employ halal financing if they have sufficient information about its characteristics and advantages and believe it is consistent with the Islamic banking philosophy. Consequently, the following hypotheses were developed:-

- H3: Religiosity has a positive effect on the intention to use halal financing
- H4: Religiosity mediates the relationship between attitudes and intention to use halal financing
- H5: Religiosity mediates the relationship between subjective norms and intention to use halal financing

METHODOLOGY

Research Instrument

Data was gathered using an online survey form. To create the questionnaire, the following processes were followed. First, a draught version of the questionnaire in English was created based on past research. Second, the draught version was pretested by three academics and changed based on their feedback. Third, the author translated the questionnaire into the Malay language, which is Malaysia's national language. Fourth, four academics fluent in Malay and English and with more than ten years of expertise in Islamic banking and marketing reviewed the translation. Finally, convenience sampling was used to acquire pilot data.

The Muslim customers of the bank were selected randomly and invited to participate in the pilot study. The pilot study was conducted with 69 respondents from Malaysia, and Cronbach's Alpha was calculated for each construct to measure the internal consistency of the questionnaire items. The

results of the pilot study indicated that Cronbach's alphas of each construct met the standard of 0.7 suggested by Nunnally (1978). There are two primary elements to the online survey questionnaire. The first part includes demographic information, such as gender, marital status, age, education, and occupation. The study's items were evaluated using a five-point Likert scale in the second half, with 1 denoting strong disagreement and 5 denoting strong agreement.

Data Collection & Sample

This study's target population consisted of Malaysians over the age of 18. To ensure that respondents understood the idea clearly, an explanation of halal funding was supplied at the beginning of the questionnaire. Due to a lack of access to the sample frame, the study employed a convenience sampling approach.

Respondent information was gathered via an online survey. Customers that utilise halal financing intervened and were allowed to take part. Because convenience sampling was employed to get the data, sample selection bias might affect the findings. Data were gathered to reflect population heterogeneity at various times of day, on various days of the week, and in various locations within two chosen provinces to guard against potential sample selection bias. This poll was carried out between May and July 2021. 211 of the 220 targeted surveys sent out and returned had answers. The profile of the responders is shown in Table 1 below:

Table 1. Respondents' Profile (N=211)

Characteristics		Frequency	%
Gender	Male	111	52.6
	Female	100	47.4
Marital Status	Single	80	37.9
	Married	131	62.1
Age	18-25 Years Old	35	16.6
	26-35 Years Old	54	25.6
	36-45 Years Old	40	19.0
	46-55 Years Old	40	19.0
Education	56 Years Old and Above	42	20.0
	High School	20	9.5
	Diploma	35	16.6
	Bachelor's Degree	113	53.6
	Masters' Degree	25	11.8
Occupation	Ph. D	18	8.5
	Government Sector	150	71.1
	Private Sector	38	18.0
	Self-Employed	19	9.0
	Student	2	1.0
	Unemployed	2	1.0

Analysis Requirement

This study analysed the effects of attitudes, subjective norms, and religiosity on the intention to utilise halal financing as well as the mediating effect of religion using the Structural Equation Modeling (SEM) approach. Due to the study's predictive nature and the conceptual framework's intricacy, this approach was chosen (Hair et al., 2019). A two-step procedure was adopted for assessing the suggested conceptual framework in accordance with Hair et al. (2019). The constructs' reliability and validity were assessed in the first stage, and the importance of the links between them was assessed in the second (Awang, 2015).

Moreover, the SEM technique of contrasting various models to judge relative model fit makes it a more robust because regression is especially sensitive to erroneous interpretations by misspecification. To calculate the goodness of fit indices and assess how well the data matched the model in this investigation, SPSS AMOS 24 was utilised.

Table 2. Model Fit and Level of Acceptance

Name of category	Name of index	Level of acceptance
1. Absolute fit	Chi-Square	P-value > 0.05 (not applicable for large sample size more than 200)
	RMSEA	RMSEA < 0.08
	GFI	GFI > 0.90
2. Incremental fit	AGFI	AGFI > 0.90
	CFI	CFI > 0.90
	TLI	TLI > 0.90
	NFI	NFI > 0.90
3. Parsimonious fit	Chisq/df	Chi-Square/ df < 3.0

***The indexes in bold are recommended since they are frequently reported in the literature. Source: Awang (2015)

The fitness indices show how well the items are suited to measure each latent component. Table 2 above lists the Fitness Indexes, the categories they fall under, and their level of approval.

FINDINGS

Reliability Analysis

Cronbach's Alpha was used to test the reliability of the instruments. Nunnally (1978) noted that Cronbach's Alpha value should be greater than the minimum standard of 0.7.

Table 3: Reliability Analysis

Latent Variables	No. of Observed Variables	Cronbach's Alpha
Intention (INT)	4	0.701
Attitudes (ATT)	5	0.871
Subjective Norms (SNorms)	3	0.879
Religiosity (Rel)	4	0.850

Table 3 shows the reliability result for each latent variable tested in this study. The result indicates reasonable internal consistency reliability estimates as the values range between 0.700 and 0.879.

Confirmatory Factor Analysis

In this investigation, the first and final measurement models from the confirmatory factor analysis (CFA) are employed (Awang, 2015). The initial stage in developing two CFA models was to add the scale items as "measured variables" and the item groupings as "latent variables." If the fit is good, the second model, in which the sub-scales are the "latent variables" and the item groups are the "measured variables," follows. Before assessing the structural model, it is necessary to examine the factorial validity of the proposed measurement model. The initial measurement model is shown in Figure 3, and the final model is shown in Figure 4.

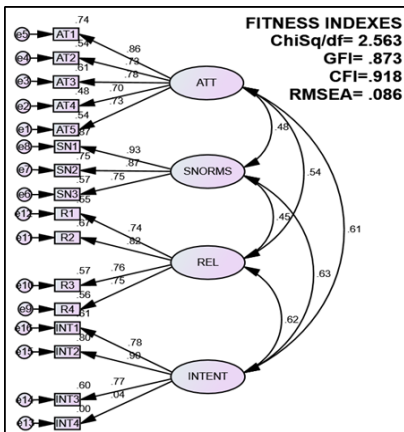

Figure 3. The First Model of CFA

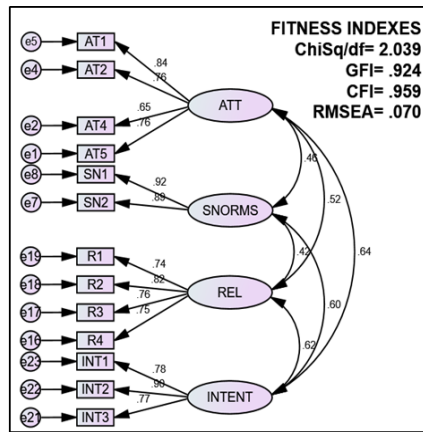

Figure 4. The Final Model of CFA

The root mean square of error approximation (RMSEA) should be less than 0.08, the goodness of fit index (GFI) and comparative fit index (CFI) should be greater than 0.9. The chi-square/degrees of freedom (Chisq/df) should

be less than 3.0, according to the rule of thumb, and these are the so-called uni-dimensionality tests (Awang, 2015).

Table 4. Validity Tests

Latent Variables	Convergent Validity	
	CR (> 0.7)	AVE (> 0.5)
Attitudes (ATT)	0.73	0.57
Subjective Norms (SNORMS)	0.78	0.82
Religiosity (REL)	0.77	0.59
Intention (INT)	0.75	0.65

The next step is to evaluate convergent validity, which is a determination of the convergence or proportion of variance shared by a construct's indicators. It is acceptable to have a CR value of 0.7 or higher and an appropriate AVE value of 0.50 or higher. The CR and AVE result further support table 4's presentation that the most recent factors investigated in this study are satisfied.

Structural Model

It is possible to quantify the proposed relationship between the dependent and independent variables using path coefficients. The structural model output created and the route coefficient findings for every tested connection are shown in Tables 5, 6, and Figure 5 and are all significant. This study developed a total of 5 hypotheses, and the outcomes for all associations are reported in Tables 5, Tables 6, and Figure 5.

Table 5. Path Analysis Results (Direct Effects)

	Estimate	S.E.	C.R.	P	Decision
H1	.506	.124	4.091	***	Supported
H2	.267	.062	4.325	***	Supported
H3	.370	.089	4.157	***	Supported

Table 6. Path Analysis Results (Indirect Effects)

	Estimate	S.E.	C.R.	P	Decision
H4	.556	.121	4.579	***	Supported (Partial Mediation)
H5	.179	.063	2.861	.004	Supported (Full Mediation)

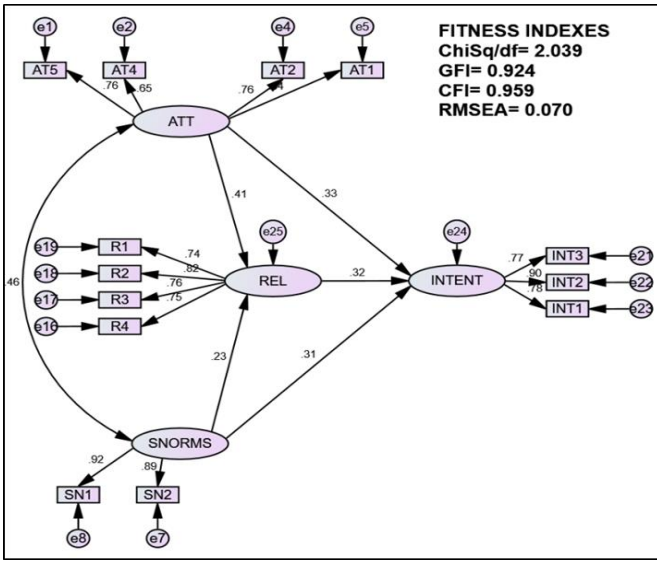

Figure 5. Structural Model

As a consequence, these path results indicated that the study's hypotheses were achieved. The decision to pick halal funding is significantly influenced by a person's opinions, subjective norms, and level of religion. The relationship between attitudes and intention to use halal financing is mediated by religion, as is the relationship between subjective norms and intention to use halal financing (since the direct effect is greater than the indirect effect, mediation occurs and the type of mediation here is partial mediation effect) (since the indirect effect is more prominent than direct effect, mediation occurs and the type of mediation here is full mediation effect).

CONCLUSIONS & RECOMMENDATIONS

The primary goals of this study were to examine the factors that influence the decision to utilise halal financing and to determine the influence of Malaysian Muslims' level of religiosity on the strength of the connections. As a starting point, the TRA was used, and it was then further modified by the addition of the mediator role of religion. They accepted the hypotheses. The desire to employ halal financing is positively influenced by attitudes, subjective norms, and religion. Additionally, religion acts as a mediator between attitudes and intention, subjective norms, and the intention to employ halal funding.

The outcomes of this study suggest that the significant factor is in line

with those of other investigations. This finding suggests that higher levels of attitudes, subjective norms, and religiosity will have a strong positive influence on a person's intention to use halal financing. This is expected in a collectivist society like Malaysia, where people conform to norms based on attitudes, recommendations from friends and family, and religiosity and its mediating effect. Therefore, it is essential to make it clear that halal finance is carried out following Islamic law if you want to market it successfully among religious clients.

In terms of theoretical implications, this study extends TRA theory by adding variables. The results showed that in addition to attitudes and subjective norms, religiosity also has an effect on intention in the context of halal financing. Furthermore, the results indicated that religiosity has a mediation effect towards the intention to use halal financing. Therefore, religiosity must be considered when applying TRA in explaining a customer's attitude, subjective norms, and behavioural intentions.

In terms of practical contributions, the results of this study have important implications for the managers and marketers of Islamic banks. They can use the results of the study to formulate strategies for attracting increasing numbers of customers to halal financing. As attitude, subjective norms, and religiosity play a predominant role in motivating Muslims to use halal financing, Islamic bank managers should give special attention to the factors that can create an intention to use halal financing among Muslims. According to the results, the significant positive effect of attitudes, subjective norms, religiosity towards intention, and religiosity plays an essential role as mediation effect towards intention indicated that they are crucial factors in implementing halal financing in line with Islamic rules and showing clearly how it differs from the practices of conventional banks.

Therefore, Islamic banks should conduct halal financing contracts in such a manner that they encompass justice, fairness, honesty, and integrity, and they should ensure that any halal financing contracts are strictly adherent to and compliant with all the standards and rules set forth by Islamic principles and regulations. Considering the significant influence of religiosity as a mediator on intention, policymakers should integrate the information on compliance of halal financing with religiosity into school and university courses. As attitudes, subjective norms, and religiosity are also essential drivers towards intention to use halal financing, Islamic banks should provide a platform for existing customers of halal financing to share their experiences with others and should motivate them to inform others about all the benefits of halal financing offers

its users. Islamic banks can reward those existing customers that have persuaded and attracted other potential customers to use halal financing in the future.

ACKNOWLEDGMENTS

This research was presented at the International Halal Conference 2022 (INHAC) and awarded as the best paper. The authors would like to thank the Academy of Contemporary Islamic studies as the organiser, for the support in funding the presentation of this research.

CONFLICT OF INTEREST

The authors declare no competing interests such as financial or personal relationships with regard to the writing of this article.

AUTHORS' CONTRIBUTION

Siti Nor Amira Mohamad was assigned to conceptualization, gathering the literature, analysis and writing. Mohamad Yazis Ali Basah supervised the methods and the results, then inspect the data as well as conceptualization.

REFERENCES

- Alzadjal, M.A.J., Abu-Hussin, M.F., Md Husin, M. and Mohd Hussin, M.Y. (2021), "Moderating the role of religiosity on potential customer intention to deal with Islamic banks in Oman", *Journal of Islamic Marketing*, Vol. ahead-of-print No. ahead-of-print. <https://doi.org/10.1108/JIMA-05-2020-0150>
- Amin, H. (2017). "Consumer behaviour of Islamic home financing: Investigating its determinants from the theory of Islamic consumer behaviour", *Humanomics*, Vol. 33 No. 4, pp. 517–548. <https://doi.org/10.1108/H-12-2016-0102>
- Awang Z. Universiti Teknologi MARA Press, Malaysia, 2012. 633*, (2012). *SEM Made Simple*. Z Awang. MPWS Publisher, 2015.
- Bananuka, J., Mukyala, V., Tumwebaze, Z., Ssekakubo, J., Kasera, M. and Najjuma, M.S. (2020), "The intention to adopt Islamic financing in emerging economies: evidence from Uganda", *Journal of Islamic Accounting and Business Research*, Vol. 11 No. 3, pp. 610–628. <https://doi.org/10.1108/JIABR-07-2017-0108>
- Basah, M. Y. A. & Mohamad, S. N. A. (2021). *Credit Risk Assessment of Microfinancing Among Asnaf: Challenges and Solutions*, 2nd Kedah International Zakat Conference (KEIZAC)
- Effendi, I., Murad, M., Rafiki, A. and Lubis, M.M. (2021), "The application of

- the theory of reasoned action on services of Islamic rural banks in Indonesia", *Journal of Islamic Marketing*, Vol. 12 No. 5, pp. 951–976. <https://doi.org/10.1108/JIMA-02-2020-0051>
- Ha, L. C. (1998), "The theory of reasoned action applied to brand loyalty", *Journal of Product & Brand Management*, Vol. 7 No. 1, pp. 51-61. <https://doi.org/10.1108/10610429810209737>
- Hair, J.F., Risher, J.J., Sarstedt, M. and Ringle, C.M. (2019), "When to use and how to report the results of PLS-SEM", *European Business Review*, Vol. 31 No. 1, pp. 2-24. <https://doi.org/10.1108/EBR-11-2018-0203>
- Amin H., Abdul Rahim Abdul Rahman Dzuljastri Abdul Razak, (2014). "Consumer acceptance of Islamic home financing", *International Journal of Housing Markets and Analysis*, Vol. 7 Iss 3 pp. 307 – 332
- Hati, S.R.H., Wibowo, S.S. and Safira, A. (2021). "The antecedents of Muslim customers' intention to invest in an Islamic bank's term deposits: evidence from a Muslim majority country", *Journal of Islamic Marketing*, Vol. 12 No. 7, pp. 1363–1384. <https://doi.org/10.1108/JIMA-01-2020-0007>
- Himel, M.T.A., Ashraf, S., Bappy, T.A., Abir, M.T., Morshed, M.K. and Hossain, M.N. (2021), "Users' attitude and intention to use mobile financial services in Bangladesh: an empirical study", *South Asian Journal of Marketing*, Vol. ahead-of-print No. ahead-of-print. <https://doi.org/10.1108/SAJM-02-2021-0015>
- Jamshidi, D. and Hussin, N. (2018). "An integrated adoption model for Islamic credit card: PLS-SEM based approach", *Journal of Islamic Accounting and Business Research*, Vol. 9 No. 3, pp. 308–335. <https://doi.org/10.1108/JIABR-07-2015-0032>
- Johan, Z.J., Hussain, M.Z., Mohd, R. and Kamaruddin, B.H. (2020), "Muslims and non-Muslims intention to hold Shariah-compliant credit cards: a Smart-PLS approach", *Journal of Islamic Marketing*, Vol. ahead-of-print No. ahead-of-print. <https://doi.org/10.1108/JIMA-12-2019-0270>
- Junaidi, J., Wicaksono, R. and Hamka, H. (2021). "The consumers' commitment and materialism on Islamic banking: the role of religiosity", *Journal of Islamic Marketing*, Vol. ahead-of-print No. ahead-of-print. <https://doi.org/10.1108/JIMA-12-2020-0378>
- Jusoh, Z. M., Rahiman, N., & Saworo, S. N. W. (2021). "Factors Influencing Consumer Purchasing Behaviour Towards Online Food Delivery Services", *Malaysian Journal of Consumer and Family Economics*, Vol 27, p. 131.-146.
- Khan, A., Arafat, M.Y. and Azam, M.K. (2020), "Role of halal literacy and religiosity in buying intention of halal branded food products in India", *Journal of Islamic Marketing*, Vol. ahead-of-print No. ahead-of-print. <https://doi.org/10.1108/JIMA-08-2019-0175>
- Kusumawati, A., Listyorini, S., S. and Yulianto, E. (2019). "The impact of religiosity on fashion knowledge, consumer-perceived value and

- patronage intention", *Research Journal of Textile and Apparel*, Vol. 23 No. 4, pp. 269-290. <https://doi.org/10.1108/RJTA-04-2019-0014>.
- Magli, A. S., Sabri M. F., Rahim, H. A., & Othman, M. A. (2022). Payment Behaviour Among B40 Households During COVID-19 as a Mediator Towards Financial Well-Being. *Malaysian Journal of Consumer and Family Economics*, Vol 28, p. 1-32.
- Mohamad, S. N. A., Basah, M. Y. A., Aziz, M. R. A., Khairi, K. F., Laili, N. H., Sabri, H. & Yusuf, M. M. (2014). Islamic Credit Risk Management in Murabahah Financing-The Study of Islamic Banking in Malaysia. *Australian Journal of Basic and Applied Sciences (AJBAS)*, 8(6), 318-323.
- Mohamad, S. N. A. Basah, M. Y. A., Aziz, M. R. A., Khairi, K. F., Laili, N. H., Sabri, H. & Yusuf, M. M. (2016). Exploring Customers' Awareness towards Profit-and-Loss Sharing Contracts in Managing Risks. *The 3rd International Muamalat & Entrepreneurship Conference (IMEC 3)*. The Everly Hotel, Putrajaya.
- Mohamad, S.N.A., Basah, M.Y.A., Aziz, M.R.A. (2019). An Exploration of Banks' managers' perceptions Towards Equity-Based Financing Practices In Malaysia, *International Journal of Accounting*, vol.4, no.17.
- Mohamad, S. N. A. & Basah, M. Y. A. (2021). Determinants of Intention to Adopt Equity-based Financing during Pandemic Covid-19: Malaysian Users' of Financing Perspective. *International Conference on Contemporary Islamic Studies (ICIS)*, UITM.
- Mohd Thas Thaker, H., Khaliq, A., Mohd Thas Thaker, M.A.B., Allah Pitchay, A.B. and Sakaran, K.C. (2021), "Drivers of Ar-Rahnu (pawn) acceptance: Malaysian evidence", *Journal of Islamic Marketing*, Vol. 12 No. 7, pp. 1241–1259. <https://doi.org/10.1108/JIMA-08-2019-0161>
- Nunnally, J. C. (1978). *Psychometric theory* (2nd ed.). New York: McGraw-Hill.
- Sharif, S., Ahson, S. and Noor, H. (2020). "Al Meezan Investment Management Limited: evolution of Shariah-compliant mutual funds", *Emerald Emerging Markets Case Studies*, Vol. 10 No. 4. <https://doi.org/10.1108/EEMCS-12-2019-0339>
- Suhartanto, D. (2019). "Predicting behavioural intention toward Islamic bank: a multi-group analysis approach", *Journal of Islamic Marketing*, Vol. 10 No. 4, pp. 1091-1103. <https://doi.org/10.1108/JIMA-02-2018-0041>
- Suhartanto, D., Dean, D., Ismail, T.A.T. and Sundari, R. (2020). "Mobile banking adoption in Islamic banks: Integrating TAM model and religiosity-intention model", *Journal of Islamic Marketing*, Vol. 11 No. 6, pp. 1405–1418. <https://doi.org/10.1108/JIMA-05-2019-0096>
- Suhartanto, D., Dean, D., Ismail, T.A.T. and Sundari, R. (2020). "Mobile banking adoption in Islamic banks: Integrating TAM model and religiosity-intention model", *Journal of Islamic Marketing*, Vol. 11 No.

- 6, pp. 1405–1418. <https://doi.org/10.1108/JIMA-05-2019-0096>
- Troudi, H. and Bouyoucef, D. (2020). "Predicting purchasing behaviour of green food in Algerian context", *EuroMed Journal of Business*, Vol. 15 No. 1, pp. 1-21. <https://doi.org/10.1108/EMJB-03-2019-0046>
- Wulandari, P., Putri, N.I.S., Kassim, S. and Sulung, L.A. (2016), "Contract agreement model for murabahah financing in Indonesia Islamic banking", *International Journal of Islamic and Middle Eastern Finance and Management*, Vol. 9 No. 2, pp. 190–204. <https://doi.org/10.1108/IMEFM-01-2015-0001>
- Yaya, R., Saud, I.M., Hassan, M.K. & Rashid, M. (2021). "Governance of profit and loss sharing financing in achieving socio-economic justice", *Journal of Islamic Accounting and Business Research*, Vol. 12 No. 6, pp. 814–830. <https://doi.org/10.1108/JIABR-11-2017-0161>
- Zhikun, D. and Fungfai, N. (2009). "Knowledge sharing among architects in a project design team: An empirical test of theory of reasoned action in China", *Chinese Management Studies*, Vol. 3 No. 2, pp. 130–142. <https://doi.org/10.1108/17506140910963639>